

Process Gas Mass Flow Meters and Controllers

FEATURES

- Direct monitoring of mass flow eliminates need for ancillary pressure and temperature sensing
- Patented straight sensor tube with access ports permits easy cleaning and reduces maintenance down-time
- Platinum sensor eliminates zero-drift and ensures long-term repeatability
- Fast-response control valve provides rapid response to set point changes and operates over a wide pressure differential range
- Primary standard calibration ensures starting point accuracy and NIST traceability
- Available with a wide variety of enclosures, process connections, input/output options and control electronics
- CE Approved

SideTrak 830/840



DESCRIPTION

Sierra Instruments' SideTrak® 830 Mass Flow Meters and 840 Mass Flow Controllers are designed for precise measurement and control of air and process gases in ranges from 0 to 10 sccm up to 0 to 500 slpm. Because all wetted materials are 316 stainless steel, the device accommodates most clean gases, including corrosives.

Proven by over 25 years of field installations, the SideTrak product line is distinguished by its patented, cleanable, large-diameter sensor tube and the reliability and serviceability that this feature provides. Because a microscopic layer of contamination has a major effect on small diameter sensor tubes, many mass flow meters and controllers suffer, over time, from degradation of accuracy or repeatability.

The SideTrak sensor is not only larger in diameter than most other MFMs and MFCs, but it is mounted along the side of the flow body to provide access ports at either end. In the event of clogging or contamination, it can be cleaned with the 0.03-inch diameter cleaning rod available from Sierra.



SIERRA

上海萨海测量技术有限公司
电话: 021-6236 2960
传真: 021-5235 2321
邮箱: sales@seasy-ist.com
网址: www.seasy-ist.com



DESCRIPTION (continued)

Sierra's SideTrak® sensor also overcomes the problem of zero-drift commonly associated with capillary-type meters and controllers. Because the sensor windings are constructed of platinum, the NIST standard for temperature detection and one of the most stable elements known, the device is virtually drift-free.

Sierra's 840 features a built-in electromagnetic servo-control valve that provides precise, instantaneous control of gas delivery to a test, batch or continuous process operation. Speed-of-response, accuracy and reliability characterize the 840 and have made it the instrument of choice in a wide variety of gas flow control applications—from laboratory and test benches to instrument OEMs, in analytical and process industries, and as a transfer standard in metrology labs.

SideTrak's broad range of sizes, control electronics, process connections, enclosures, input/output options, cables and connectors provide flexibility, versatility—ultimately, the ideal instrument package for your specific application.

LOW FLOW BODY

Flow Range	
0-10 sccm to 0-15 slpm	
Process Tubing	.25 (6.4)

Fitting Type, .562-18 Thread ⁽¹⁾			
	Compression .125 or .25	VCO (male) .25	VCR (male) .25
Dim. L	4.84 or 5.0	4.60	4.90

MEDIUM FLOW BODY

Flow Range, slpm				
	0-15	0-30	0-50, 100	0-100
Process Tubing	.25 or .375 (6.4 or 9.5)	.25 or .375 (6.4 or 9.5)	.25 or .375 (6.4 or 9.5)	.375 (9.5)

Fitting Type, .562-18 Thread ⁽¹⁾			
	Compression .25 or .375	VCO (male) .25 or .375	VCR (male) .25 or .375
Dim L.	6.27 or 6.39	5.81 or 6.25	.613 or 6.25

Note: (1) Metric fittings are available, consult factory.

All dimensions are inches. Millimeters are in parentheses. Certified drawings are available on request.

830L/840L — Front View

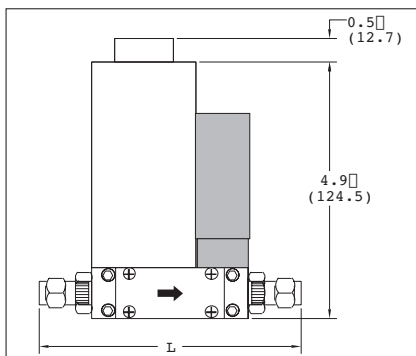

830L/840L — Bottom View

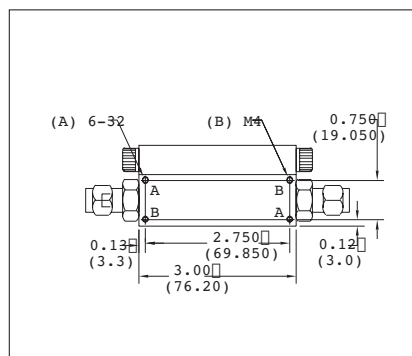

830M/840M — Bottom View

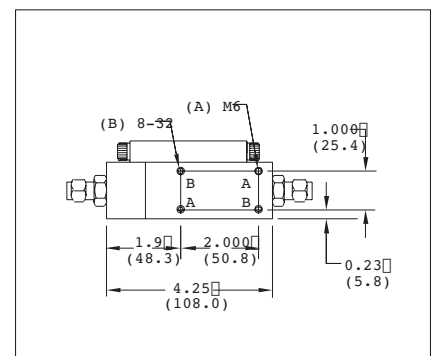

830M/840M — Front View

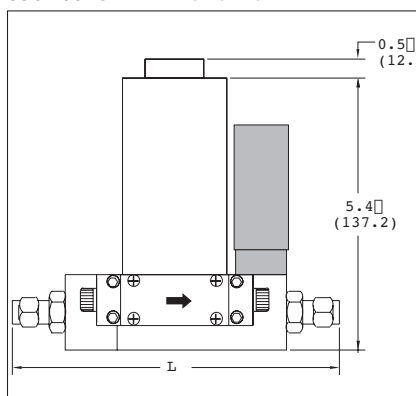

830L/840L — Outlet View

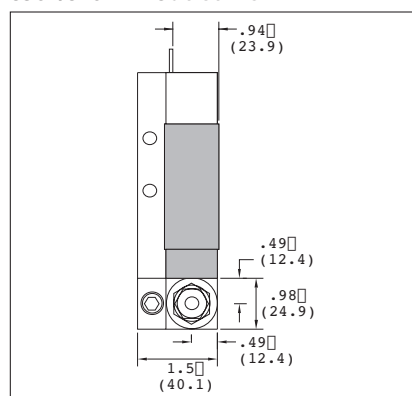

830M/840M — Outlet View

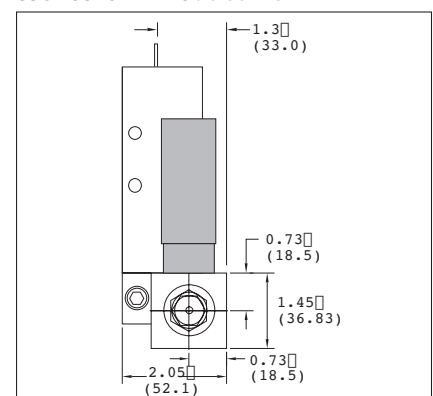

Shaded portion of dimensional drawings indicates Model 840 controllers.

HIGH FLOW BODY

Flow Range, slpm					
	0-100	0-200	0-300	0-400	0-500
Process Tubing	.375 or .50 (9.5 or 12.7)	.375 or .50 (9.5 or 12.7)	.50 (12.7)	.50 (12.7)	.50 (12.7)

Fitting Type, .75-16 Thread ⁽¹⁾			
	Compression .375 or .50	VCO (male) .375	VCR (male) .375
Dim. L 830	11.90 or 12.10 (302.3 or 307.3)	11.80 (299.7)	12.19 (309.6)
Dim. L2 840	14.10 or 14.30 (358.1 or 363.2)	14.00 (355.6)	14.40 (365.8)

Note: (1) Metric fittings are available, consult factory.

All dimensions are inches. Millimeters are in parentheses. Certified drawings are available on request.

830H/840H — Front View

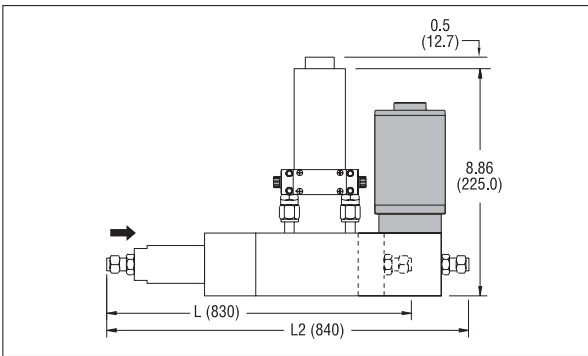

830H/840H — Bottom View

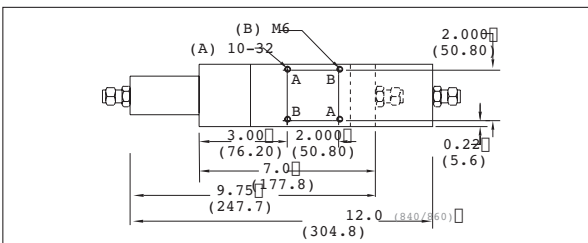

830H/840H — Outlet View

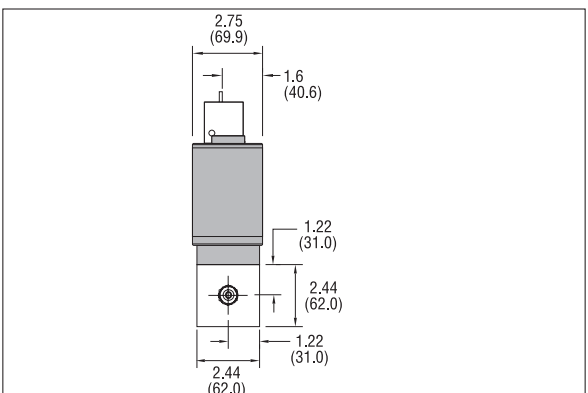

Shaded portion of dimensional drawings indicates 840 controllers.

PERFORMANCE SPECIFICATIONS

Accuracy

+/- 1% of full scale under calibration conditions including linearity over 59°F to 77°F (15°C to 25°C) and 10 to 60 psia (0.7 to 4 bara); +/- 2% of full scale including linearity under calibration conditions over 32°F to 122°F (0°C to 50°C) and 5 to 150 psia (0.3 to 10 bara); +/- 1% of full scale accuracy at a specific temperature and pressure is available with special calibration.

If the meter is mounted with a vertical (up or down) flow path the following accuracy de-rating applies:

Operating Pressure ⁽¹⁾			
Inlet Pressure Deviation ⁽¹⁾	50 psig	100 psig	150 psig
+/- 1 psig	+/- 1% of full scale	+/- 1% of full scale	+/- 1% of full scale
+/- 5 psig	+/- 2.5% of full scale	+/- 3% of full scale	+/- 3.5% of full scale
+/- 10 psig	+/- 4% of full scale	+/- 5% of full scale	+/- 6% of full scale

Notes: (1) Do not exceed 150 psig.

(2) Difference between inlet pressure and calibrated pressure. Do not exceed +/- 10 psig.

Repeatability

+/- 0.15% of full scale

+/- 0.5% of full scale for 840 (NPT)

Temperature Coefficient

0.08% of full scale per °F (0.15% of full scale per °C), or better

Pressure Coefficient

0.01% of full scale per psi (0.15% of full scale per bar), or better

Response Time ⁽¹⁾

- 830 (all) 300 ms time constant; 2 second (typical) to within +/-2% of set point over 20 to 100% of full scale
- 840 (low, med) 300 ms time constant; 2 second (typical) to within +/-2% of set point over 20 to 100% of full scale
- 840 (high) 600 ms time constant; 4 seconds (typical) to within +/-2% of set point over 20 to 100% of full scale

Notes: Option available on 840 low, medium and high flow bodies of 1.5 second time constant, others on special order.

OPERATING SPECIFICATIONS

Gases

All clean gases; specify when ordering

Mass Flow Rate

0 to 10 sccm to 0 to 500 slpm; flow ranges specified are for an equivalent flow of nitrogen at 760 mm Hg and 21°C (70°F); other ranges in other units are available (e.g., scfh or nm³/h)

Gas & Ambient Temperature

32° to 176°F (0 to 80°C); above 122°F (50°C) requires HT or RT option.

Gas Pressure

500 psig (34 barg) maximum;
30 psig (2 barg) optimum

Leak Integrity

5 X 10⁻⁹ atm cc/sec of helium maximum

Power Requirements

830 (all) +15 VDC @ 80 mA, 1.2 watts and
-15 VDC @ 10 mA, 0.15 watts
840 (low) +15 VDC @ 130 mA, 2 watts and
-15 VDC @ 200 mA, 3.0 watts
840 (med) +15 VDC @ 400 mA, 6 watts and
-15 VDC @ 300 mA, 4.5 watts
840 (high) +15 VDC @ 1.13 A, 17 watts and
-15 VDC @ 1.06 A, 16 watts

Control Range

840 (all) 2 to 100% of full scale;
valve shuts between 1.0% to 2.5% of full scale

Command Signal (For 840 Only)

0 to 5 VDC, 20 megaohms minimum input impedance
4 to 20 mA, 250 ohms maximum input impedance

Output Signal

Linear 0 to 5 VDC, 1000 ohms minimum load resistance
Linear 4 to 20mA, 500 ohms maximum loop resistance

PHYSICAL SPECIFICATIONS

Wetted Materials

830 (all) 316 stainless steel, Viton® "O"-rings standard; Neoprene and 4079 Kalrez® optional;
others on special order
840 (low, med, high) 316 stainless steel, 430F stainless steel, Viton® "O"-rings and valve seat standard;
Neoprene, 4079 Kalrez® and other elastomers available on special order; PFA Teflon® valve seat available

Control Valve Type

840 (low, med, high) Electromagnetic

Differential Pressure Requirements ΔP , For 840

30 psi (2.1 bar) differential optimum for all controllers

840 (low) .010 - 15 slpm:

5 to 50 psi (0.3 to 3.4 bar) differential standard;

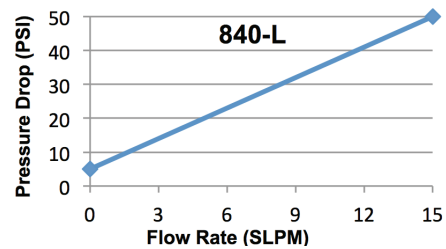

840 (med) 15 to 50 slpm:

5 to 50 psi (0.3 to 3.4 bar) differential;

51 to 100 slpm: 10 to 40 psi (0.7 to 2.8 bar) differential standard;

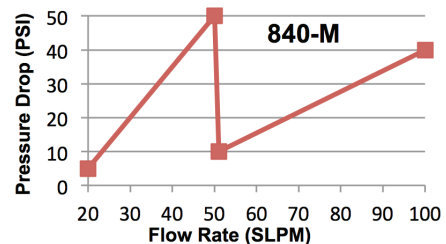

840 (high) 100 to 200 slpm:

10 to 50 psi (0.7 to 3.4 bar) differential;

201 to 500 slpm:

10 to 40 psi (0.7 to 2.8 bar) differential standard;

lower or higher ΔP available on special order

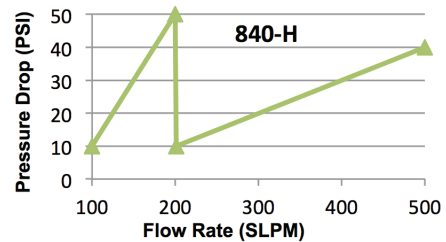

Pressure Drop Across The 830

Flow Meter	Flow Rate	psi			Mbar		
		1/4	3/8	1/2	1/4	3/8	1/2
Meter Fittings (inch) →		1/4	3/8	1/2	1/4	3/8	1/2
830-L	100 sccm	.005	n/a	n/a	.309	n/a	n/a
830-L	500 sccm	.006	n/a	n/a	.440	n/a	n/a
830-L	1 slpm	.006	n/a	n/a	.475	n/a	n/a
830-L	15 slpm	.11	.06	n/a	7.59	4.0	n/a
830-M	20 slpm	.08	.03	n/a	5.50	2.0	n/a
830-M	50 slpm	n/a	.3	.10	n/a	20.4	6.8
830-M	100 slpm	2.0	.85	.30	136	58	20.4
830-H	200 slpm	n/a	2.50	2.00	n/a	170	136
830-H	500 slpm	n/a	n/a	8.5	n/a	n/a	578

ORDERING THE 830/840

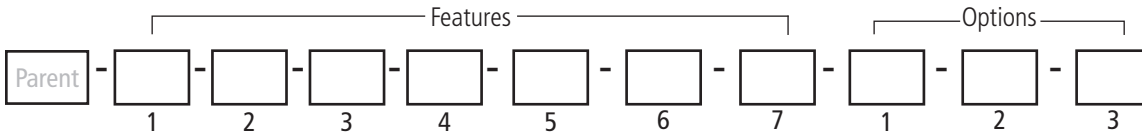

Instructions: To order the 830/840 please fill in each number block by selecting the codes from the corresponding features below and following pages.

Parent Number	
830	SideTrak® Mass Flow Meter Standard configuration includes: flow body and sensor constructed of 316 stainless steel, Viton® "O" rings; linear, 0-5 VDC output signal; requires input power ±15 VDC. Includes mating connector. Calibrated for flow ranges from 0-10 sccm to 0-500 slpm equivalent nitrogen flow; maximum temperature 122°F (50°C). Maximum pressure 150 psig (10.3 barg) for vertical (flow up or down) orientation. CE Approved when ordered with D-plug mating connector.
840	SideTrak® Mass Flow Controller Standard configuration includes: flow body and sensor constructed of 316 stainless steel, electromagnetic valves, Viton® "O" rings; linear, 0-5 VDC output signal; requires input power ±15 VDC and 0-5 VDC or 4-20 mA command signal. Includes mating connector. Calibrated for flow ranges from 0-10 sccm to 0-500 slpm equivalent nitrogen flow; maximum temperature 122°F (50°C). Maximum pressure 150 psig (10.3 barg) for vertical (flow up or down) orientation. CE Approved when ordered with D-plug mating connector.

Feature 1 : Flow Body	
830-L	830 meter, low flow. 0-10 sccm up to 0-15 slpm (also see 824S-L and M100L)
830-M	830 meter, medium flow. 0-15 slpm up to 0-100 slpm (also see 824S-M and M100M)
830-H	830 meter, high Flow. 0-100 slpm up to 0-500 slpm (also see 824S-H and M100H)
840-L	840 controller, low flow. 0-10 sccm up to 0-15 slpm (also see C50)
840-M	840 controller, medium flow. 0-15 slpm up to 0-100 slpm
840-H	840 controller, high flow. 0-100 slpm up to 0-500 slpm

Notes: All slpm flow ranges also available in nlpm.

Feature 3 : Elastomers	
OV1	Viton® for low, medium and high flow bodies
ON1	Neoprene® for low and medium flow bodies
ON2	Neoprene® for high flow bodies
OK1	Kalrez® for low flow bodies
OK2	Kalrez® for medium flow bodies
OK3	Kalrez® for high flow bodies

Feature 4 : Valve Seats*	
SV1	Viton® (standard)
SN1	Neoprene® or equivalent
SK1	Kalrez® or equivalent for low or medium flow bodies.
SK2	Kalrez® or equivalent for high flow bodies.
ST1	Teflon® or equivalent.

Notes: Available for 840 controllers only.

Feature 2 : Fittings	
1	1/8-inch compression. For low flow bodies (maximum 5 slpm)
2	1/4-inch compression. For low and medium flow bodies. (maximum 50 slpm)
3	3/8-inch compression. For low, medium and high flow bodies. (maximum 300 slpm)
4	1/2-inch compression. For medium and high flow bodies
5	1/4-inch VCO. For low and medium flow bodies (maximum 50 slpm)
6	1/2-inch VCO. For low and medium flow bodies
7	1/2-inch VCO. For high flow bodies (maximum 300 slpm)
8	1/4-inch VCR. For low and medium flow bodies (maximum 50 slpm)
9	1/2-inch VCR. For low, medium and high flow bodies
10	6 mm compression. For low and medium flow bodies (maximum 50 slpm)
11	10 mm compression. For medium and high flow bodies
12	12 mm compression. For medium and high flow bodies
13	1/4-inch FNPT adapter bushing. For low and medium flow bodies

Feature 5: Mating Connector	
E	Edge Card. 20-pin mating connector. Not CE compliant
D	D-Plug. 15-pin mating connector. Required for CE compliance

Feature 6: Output Signal	
V1	0-5 VDC, linear
V4	4-20 mA, linear

Option 1: Calibration	
HP	High pressure calibration. 100-500 psig maximum (6.9-34.5 barg)
MP	Medium pressure calibration. 40-100 psig (2.8-6.9 barg)
LF	Low flow calibration. Required for 0-20 sccm full scale flow range or less
HT	High temperature calibration. 122°-140°F (50°-60°C), electronics on flow body
RT()	Remote high temperature calibration. 140°-176°F (60°-80°C), electronics remote. Specify cable length in parentheses, maximum cable length is 10 feet (3 m). Not CE compliant.

Option 2: Certificates	
MC	Material certificates--US Mill certs on all wetted flow body parts
CC	Certificate of conformance

Option 3: O2 Cleaning	
830-O2C	O2 Cleaning for meters. Includes certification. Product cleaned for O2 service. Inspected with ultra-violet light only, double-bagged prior to shipment
840-O2C	O2 cleaning for controllers. Includes certification. Product cleaned for O2 service. Inspected with ultra-violet light only, double-bagged prior to shipment



SIERRA®

上海萨海测量技术有限公司
 电话：021-6236 2960
 传真：021-5235 2321
 邮箱：sales@seasy-ist.com
 网址：www.seasy-ist.com